



USER INSTRUCTIONS

Logix 520MD Series
Digital Positioner

FCD LGENIM0520-01 11/09

Installation
Operation
Maintenance



Table of Contents	Page
General Information	2
Unpacking	3
Logix 520MD Overview	4
Specifications	4
Principle of Operation	5
Tubing	6
Wiring	6
Cable Requirements	7
Startup	8
Logix 520MD Local Interface Operation	8
Operation of Configuration Dipswitch Setup	8
Calibrations switches	9
Quick-Cal Operation	9
Factory Reset	10
4-20 mA Analog Output Board	10
Error Codes	12
Trouble Shooting	15
Limit switches	16
Spare parts	17
Dimensions	18

1 USING FLOWSERVE VALVES, ACTUATORS AND ACCESSORIES CORRECTLY

1.1 General usage

The following instructions are designed to assist in unpacking, installing and performing maintenance as required on FLOWSERVE products. Product users and maintenance personnel should thoroughly review this bulletin prior to installing, operating or performing any maintenance.

In most cases FLOWSERVE valves, actuators and accessories are designed for specific applications with regard to medium, pressure and temperature. For this reason they should not be used in other applications without first contacting the manufacturer.

1.2 Terms concerning safety

The safety terms **DANGER**, **WARNING**, **CAUTION** and **NOTE** are used in these instructions to highlight particular dangers and/or to provide additional information on aspects that may not be readily apparent.



DANGER: indicates that death, severe personal injury and/or substantial property damage will occur if proper precautions are not taken.



WARNING: indicates that death, severe personal injury and/or substantial property damage can occur if proper precautions are not taken.



CAUTION: indicates that minor personal injury and/or property damage can occur if proper precautions are not taken.



NOTE: indicates and provides additional technical information, which may not be very obvious even to qualified personnel.

Compliance with other, not particularly emphasised notes, with regard to transport, assembly, operation and maintenance and with regard to technical documentation (e.g. in the operating instruction, product documentation or on the product itself) is essential, in order to avoid faults, which in themselves might directly or indirectly cause severe personal injury or property damage.

1.3 Protective clothing

FLOWSERVE products are often used in problematic applications (e.g. extremely high pressures, dangerous, toxic or corrosive mediums). In particular valves with bellows seals point to such applications. When performing service, inspection or repair operations always ensure, that the valve and actuator are depressurised and that the valve has been cleaned and is free from harmful substances. In such cases pay particular attention to personal protection (protective clothing, gloves, glasses etc.).

1.4 Qualified personnel

Qualified personnel are people who, on account of their training, experience and instruction and their knowledge of relevant standards, specifications, accident prevention regulations and operating conditions, have been authorised by those responsible for the safety of the plant to perform the necessary work and who can recognise and avoid possible dangers.

1.5 Installation



DANGER: Before installation check the order-no., serial-no. and/or the tag-no. to ensure that the valve/actuator is correct for the intended application.

Do not insulate extensions that are provided for hot or cold services.

Pipelines must be correctly aligned to ensure that the valve is not fitted under tension.

Fire protection must be provided by the user.

1.6 Spare parts

Use only FLOWSERVE original spare parts. FLOWSERVE cannot accept responsibility for any damages that occur from using spare parts or fastening materials from other manufactures. If FLOWSERVE products (especially sealing materials) have been on store for longer periods check these for corrosion or deterioration before using these products. Fire protection for FLOWSERVE products must be provided by the end user.

1.7 Service / repair

To avoid possible injury to personnel or damage to products, safety terms must be strictly adhered to. Modifying this product, substituting nonfactory parts, or using maintenance procedures other than outlined in this instruction could drastically affect performance and be hazardous to personnel and equipment, and may void existing warranties. Between actuator and valve there are moving parts. To avoid injury FLOWSERVE provides pinch-point-protection in the form of cover plates, especially where side-mounted positioners are fitted. If these plates are removed for inspection, service or repair special attention is required. After completing work the cover plates must be refitted.

Apart from the operating instructions and the obligatory accident prevention directives valid in the country of use, all recognised regulations for safety and good engineering practices must be followed.



WARNING: *Before products are returned to FLOWSERVE for repair or service FLOWSERVE must be provided with a certificate which confirms that the product has been decontaminated and is clean. FLOWSERVE will not accept deliveries if a certificate has not been provided (a form can be obtained from FLOWSERVE).*

1.8 Storage

In most cases FLOWSERVE products are manufactured from stainless steel. Products not manufactured from stainless steel are provided with an epoxy resin coating. This means that FLOWSERVE products are well protected from corrosion. Nevertheless FLOWSERVE products must be stored adequately in a clean, dry environment. Plastic caps are fitted to protect the flange faces to prevent the ingress of foreign materials. These caps should not be removed until the valve is actually mounted into the system.

1.9 Valve and actuator variations

These instructions cannot claim to cover all details of all possible product variations, nor can they provide information for every possible example of installation, operation or maintenance. This means that the instructions normally include only the directions to be followed by qualified personal where the product is being used for is defined purpose. If there are any uncertainties in this respect particularly in the event of missing product-related information, clarification must be obtained via the appropriate FLOWSERVE sales office.

2 UNPACKING

Each delivery includes a packing slip. When unpacking, check all delivered valves and accessories using this packing slip.

Report transport damage to the carrier immediately.

In case of discrepancies, contact your nearest FLOWSERVE location.

3 LOGIX 520MD OVERVIEW

The Logix 520MD is a two-wire, 4-20 mA input digital valve positioner with HART communication. The Logix 520MD positioner controls single-acting actuators with linear and rotary mountings. The Logix 520MD is completely powered by the 4-20 mA input signal. The minimum input signal required to function is 3,6 mA.

Since the positioner is insensitive to supply pressure changes and can handle supply pressures from 1,5 to 6 barg (22 to 87 psig), a supply regulator is usually not required; however, in applications where the supply pressure is higher than the maximum actuator pressure rating a supply regulator is required to lower the pressure to the actuator's maximum rating (not to be confused with operating range). A coalescing air filter is recommended for all applications.

4 SPECIFICATIONS

Table 1: Input Signal

Input Signal Range	4 - 20 mA (HART)
Compliance Voltage	10 VDC
Voltage Supply (maximum)	30 VDC
Minimum Required Operating Current	3,6 mA without AO 3,83 mA with AO

Table 2: Stroke Output

Feedback Shaft Rotation	Min. 15°, max 90° 40° recommended for linear applications
-------------------------	--

Table 3: Air Supply

Air Supply Quality	Free from moisture, oil and dust per IEC 770 and ISA-7.0.01
Input Pressure Range	1,5 to 6,0 bar (22 to 87 psi)
Air Consumption (steady state)	0,08 Nm ³ /h @ 1,5 bar (0,047 SCFM @ 22 psi) 0,12 Nm ³ /h @ 6,0 bar (0,071 SCFM @ 87 psi)

Table 4: Output Signal

Output Pressure Range	0 to 100% of air supply pressure
Output Flow Capacity	2,4 Nm ³ /h @ 1,5 bar (1,41 SCFM @ 22 psi) 7,0 Nm ³ /h @ 6,0 bar (4,12 SCFM @ 87 psi)

Table 5: Shipping Weights

Base Positioner without Accessories	1,2 kg (2,65 lbs)
-------------------------------------	-------------------

Table 6: Performance Characteristics (typical)

Linearity	< +/- 1,0%
Resolution	< 0,1%
Repeatability	< 0,2%
Deadband	< 0,2%

Table 7: Environmental Conditions

Operating Temperature	-40 °C to +80 °C (-40 °F to +178 °F)
Transport and Storage Temperature	-40 °C to +80 °C (-40 °F to +178 °F)
Operating Humidity	0 to 100% non-condensing

Table 8: Hazardous Area Specifications

ATEX	II 1 G Ex ia IIC T5 - T6
	II 3 G Ex ic IIC T5 - T6
FM	Class I, Division 2, Groups A,B,C,D Temp. Class. T4 Ta = 85°C
	Class I Zone = Group IIC T4 Ta = 85°C
	Class I, Division 2, Groups A,B,C,D Temp. Class. T4 Ta = 85°C
CSA	Class I Division 1, Groups A,B,C,D
	Class I Division 2, Groups A,B,C,D

Table 9: Limit Switches (optional)

Type	P&F SJ2-S1N
Load current	< 1 mA < 3 mA
Voltage range	5 - 25 VDC
Hysteresis	0,2 %
Temperature	-25 °C to 100 °C (-13 °F to 212 °F)
Type	P&F SJ2-SN
Load current	< 1 mA < 3 mA
Voltage range	5 - 25 VDC
Hysteresis	0,2 %
Temperature	-40 °C to 100 °C (-40 °F to 212 °F)
Type	P&F SJ2-N
Load current	< 1 mA < 3 mA
Voltage range	5 - 25 VDC
Hysteresis	0,2 %
Temperature	-25 °C to 100 °C (-13 °F to 212 °F)

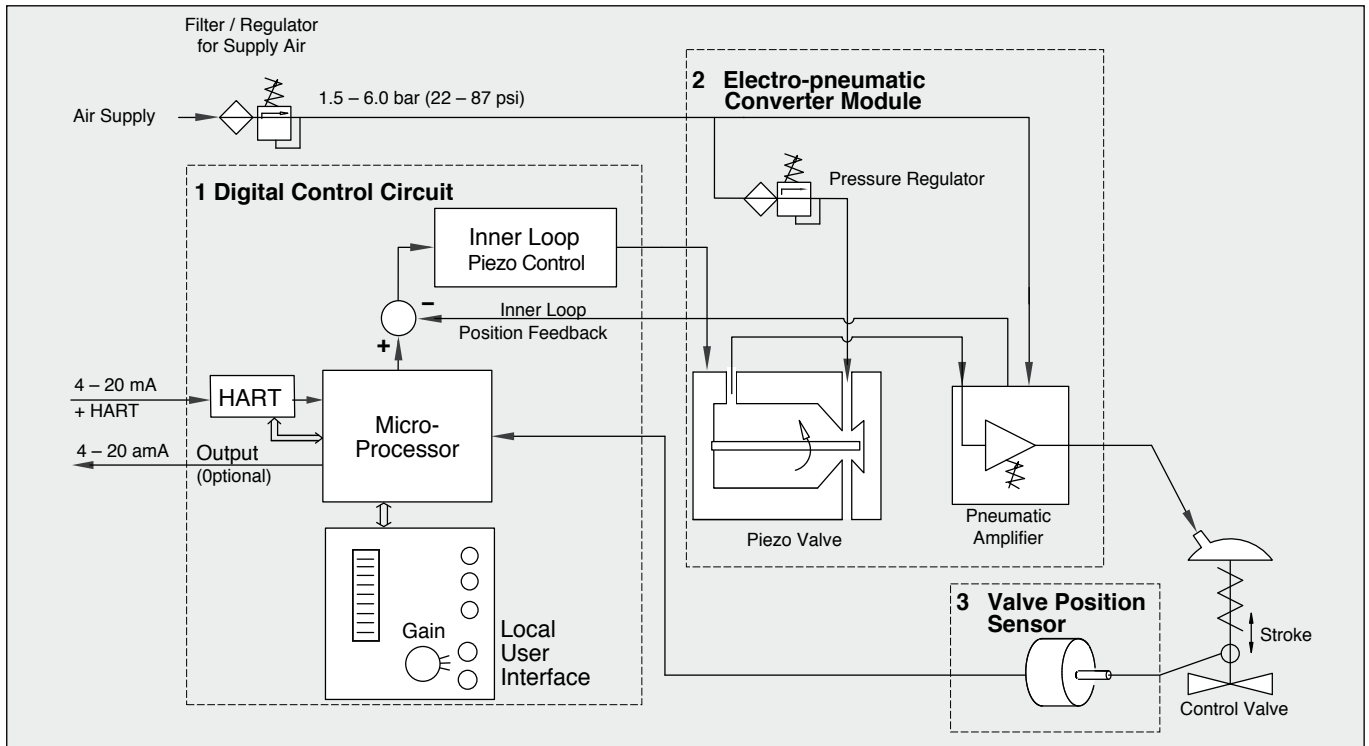

Figure 1: Logix 520MD Principle of Operation

due to the close tolerances in the positioner. Optional analog feedback system as well as limit switch unit and a directly attachable double acting module complete the Logix 520MD positioner accessories.

NOTE: *The air supply must conform to ISA 7.0.01 or IEC 770 (a dew point at least 10 °C / 18 °F below ambient temperature, particle size below five microns – one micron recommended – and oil content not to exceed one part per million).*

5 PRINCIPLE OF OPERATION

The Logix 520MD positioner is a digital positioner that incorporates HART protocol for communication. The positioner consists of three main modules:

1. The microprocessor-based electronic control module includes HART communications and direct local user interface switches
2. The piezo valve-based electro-pneumatic converter module
3. The infinite resolution valve position sensor.

The basic positioner operation is best understood by referring to Figure 1. The complete control circuit is powered by the two-wire, 4-20 mA command signal. The HART module sends and receives the superimposed FSK HART

digital communications over the 4-20 mA signal wires providing two-way remote digital communications to the microprocessor. The analog 4-20 mA command is passed to the microprocessor, where it is compared to the measured valve stem position. The control algorithm in the processor performs control calculations and produces an output command to the piezo valve, which drives the pneumatic amplifier. The position of the pilot valve in the pneumatic amplifier is measured and relayed to the inner loop control circuit. This two-stage control provides for more responsive and tighter control than is possible with a single stage control algorithm. The pneumatic amplifier controls the airflow to the actuator. The change of pressure and volume of the air in the actuator causes the valve to stroke. As the valve approaches the desired position, the difference between the commanded position and the measured position becomes smaller and the output to the piezo is decreased. This, in turn, causes the pilot valve to close and the resulting flow to decrease, which slows the actuator movement as it approaches, the new commanded position. When the valve actuator is at the desired position, the pneumatic amplifier output is held at zero, which holds the valve in a constant position.

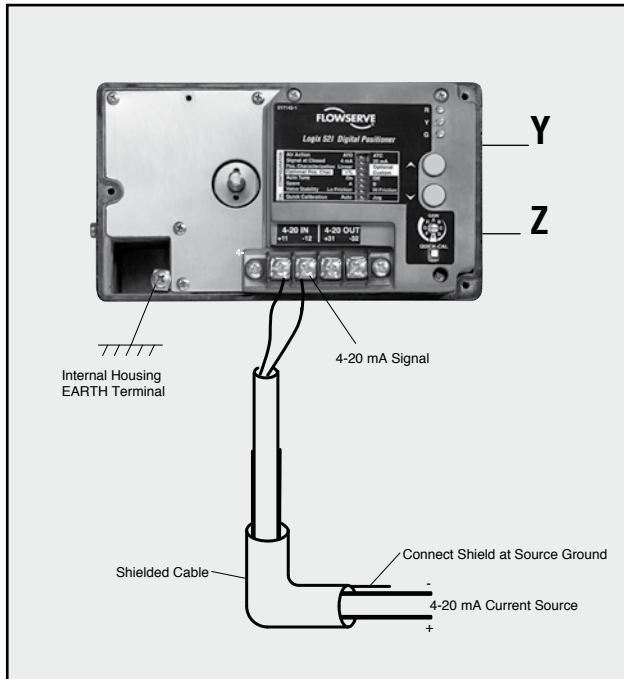

Figure 2: Wiring Diagram

6 TUBING POSITIONER TO ACTUATOR

After mounting has been completed, tube the positioner to the actuator using the appropriate compression fitting connectors:

Air connections: 1/4" NPT (standard air connection)

Auxiliary power: Pressurized air or permissible gases, free of moisture and dust in according with IEC 770 or ISA 7.0.01.

Pressure range: 1,5 – 6,0 bar (22 – 87 psi)

For connecting the air piping, the following notes should be observed:

1. The positioner passageways are equipped with filters, which remove medium and coarse size dirt from the pressurized air. If necessary, they are easily accessible for cleaning.
2. Supply air should meet IEC 770 or ISA 7.0.01 requirements. A coalescing filter should be installed in front of the supply air connection Z. Now connect the air supply to the filter, which is connected to the Logix 500si series positioner.
3. With a maximum supply pressure of 6 bar (87 psi) a regulator is not required.
4. With an operating pressure of more than 6 bar (87 psi), a reducing regulator is required. The flow capacity of the regulator must be larger than the air consumption of the positioner (7 Nm³/hr @ 6 bar / 4,12 scfm @ 87 psi).
5. Connect the outlet connector Y of the positioner to the actuator with tubing, independent of the action (direct or reverse).

Table 10: Connection Table

Connection	Description
+11	Input+ 4..20 mA
-12	Input- 4..20 mA
+31*	Output+ 4..20 mA
-32*	Output- 4..20 mA
	Limit switch 1 - separate board
	Limit switch 2 - separate board
Y (0⇒)	Pneumatic output signal (outlet)
Z (0⇐)	Air supply

* Optional

7 WIRING AND GROUNDING GUIDELINES

Electrical connections: signal cable with cable passage (NPT or M20 x 1,5) to terminals 2 x 2,5 mm

Input signal: 4 – 20 mA

! **NOTE:** Observe the minimum requirements of voltage and equivalent electrical load: 10,0 VDC / 500 Ω / at 20 mA

The performance is ensured only for a minimum input current of 3,6 mA.

For wiring, the following notes should be observed:

! **NOTE:** The input loop current signal to the Logix 520MD should be in shielded cable. Shields must be tied to a ground at only one end of the cable to provide a place for environmental electrical noise to be removed from the cable. In general, shield wire should be connected at the source. (Figure 2)

Connect the 4-20 mA current source to terminals +11 and -12 (Figure 2).

Grounding Screw

The grounding screw, located inside the positioner cover, should be used to provide the unit with an adequate and reliable earth ground reference. This ground should be tied to the same ground as the electrical conduit. Additionally, the electrical conduit should be earth grounded at both ends of its run. The grounded screw must not be used to terminate signal shield wires.

Compliance Voltage (Figure 3)

Output compliance voltage refers to the voltage limit the current source can provide. A current loop system consists of the current source, wiring resistance, barrier resistance (if present), and the Logix 520MD impedance. The Logix 520MD requires that the current loop system allow for a 10 VDC drop across the positioner at maximum loop current.

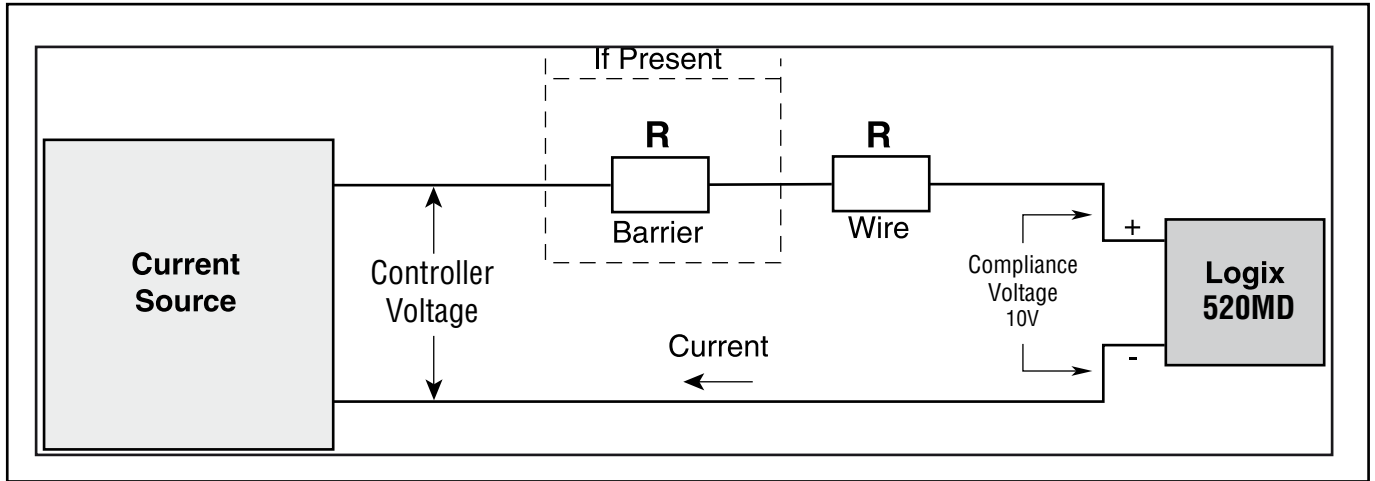

Figure 3: Compliance Voltage



CAUTION: Never connect a voltage source directly across the positioner terminals. This could cause permanent circuit board damage.

In order to determine if the loop will support the Logix 520MD, perform the following calculation:

$$\text{Available Voltage} = \text{Controller Voltage (@Current}_{MAX}) - \text{Current}_{MAX} * (R_{\text{barrier}} + R_{\text{wire}})$$

The calculated available voltage must be greater than 10 VDC in order to support the Logix 520MD.

Example:

DCS Controller Voltage = 19 V

$$R_{\text{barrier}} = 300\Omega$$

$$R_{\text{wire}} = 25 \Omega$$

$$\text{CURRENT}_{MAX} = 20 \text{ mA}$$

$$\begin{aligned} \text{Voltage} &= 19 \text{ V} - 0,020 \text{ A} * (300\Omega + 25 \Omega) \\ &= \underline{12,5 \text{ V}} \end{aligned}$$

The available voltage 12,5 V is greater than the required 10.0 V; therefore, this system will support the Logix 520MD. The Logix 520MD has an input resistance equivalent to 500 Ω at a 20 mA input current.

8 CABLE REQUIREMENTS

The Logix 520MD digital positioner utilizes the HART communication protocol. This communication signal is superimposed on the DC 4-20 mA current signal. The two frequencies used by the HART protocol are 1200 Hz and 2200 Hz. To prevent distortion of the HART communication, cable capacitance and cable length restrictions must be calculated. The cable length must be limited if the capacitance is too high. Selecting a cable with lower capacitance/mm

rating will allow longer cable runs. In addition to cable capacitance, the network resistance also affects the allowable cable length.

$$C_{\text{network}} (\mu\text{F}) \leq \frac{65\Omega}{(R_{\text{barrier}} + R_{\text{wire}} + 390\Omega)} - 0,0032$$

Example:

$$R_{\text{barrier}} = 300 \Omega \text{ (if present)}$$

$$R_{\text{wire}} = 50 \Omega$$

$$C_{\text{cable}} = \frac{72 \text{ pF}}{\text{m}} = \frac{0.000072 \mu\text{F}}{\text{m}}$$

$$\left[\frac{65}{(300 + 50 + 390)} \right] - 0,0032 = 0,08 \mu\text{F} = C_{\text{network}} (\mu\text{F})(\text{Max})$$

$$\text{Max. Cable Length} = \frac{C_{\text{network}} (\mu\text{F})}{C_{\text{cable}}}$$

$$\text{Max. Cable Length} = \frac{0,08 \mu\text{F}}{0.000072 \mu\text{F/m}} = 1111 \text{ m}$$

To control cable resistance, No. 24 AWG cable can be used for runs less than 1500 m. For cable runs longer than this, No. 20 AWG cable should be used.

Electromagnetic Compatibility

The Logix 520MD digital positioner has been designed to operate correctly in electromagnetic (EM) fields found in typical industrial environments. Care should be taken to prevent the positioner from being used in environments with excessively high EM field strengths (greater than 10 V/m). Portable EM devices such as hand-held two-way radios should not be used within 30 cm of the device.

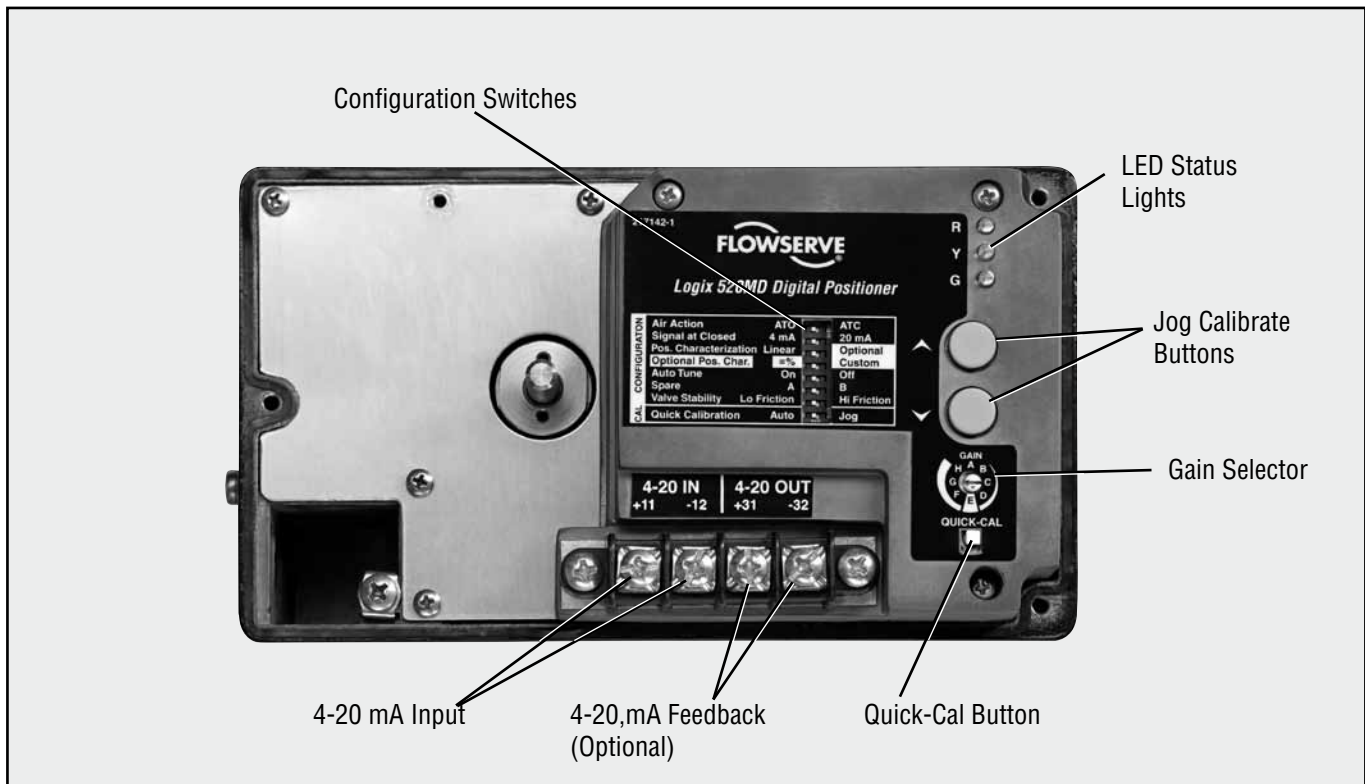

Figure 4: Logix 520MD Local Interface

Ensure proper wiring and shielding techniques of the control lines, and route control lines away from electromagnetic sources that may cause unwanted noise. An electromagnetic line filter can be used to further eliminate noise (FLOWSERVE Part Number 10156843).

In the event of a severe electrostatic discharge near the positioner, the device should be inspected to ensure correct operability. It may be necessary to recalibrate the Logix 520MD positioner to restore operation.

9 STARTUP

9.1 Logix 520MD Local Interface

The Logix 520MD local user interface allows the user to configure the basic operation of the positioner, tune the response, and calibrate the positioner without additional tools or configurators. The local interface consists of a Quick-Cal™ button for automatic zero and span setting, along with two jog buttons for spanning valve/actuators with no fixed internal stop in the open position. There is also a switch block containing eight switches. Six of the switches are for basic configuration settings, two are for calibration options. There is also a rotary selector switch for adjusting the positioner gain settings. For indication of operational status or alarm conditions there are three LEDs on the local user interface.

9.2 Initial DIP Switch Setting

Before placing the unit in service, set the DIP switches in the “Configuration” and “Cal” boxes to the desired control options.

⚠ **NOTE:** *The switch settings in the Configuration box are activated **only** by pressing the Quick-Cal button or by utilizing the stroke calibration features provided by a handheld or by Flowserve PC software.*

9.2 Operation of Configuration DIP Switches Setup

The first six DIP switches are for basic configuration

1. **Air Action** – Must be set to match the configuration of the valve/actuator mechanical configuration.

ATO (air-to-open) – Select **ATO** if increasing output pressure from the positioner is tubed so it will cause the valve to **open**.

ATC (air-to-close) – Select **ATC** if increasing output pressure from the positioner is tubed so it will cause the valve to **close**.

2. **Signal at Closed** – Normally this will be set to 4 mA for an air-to-open actuator, and 20 mA for an air-to-close actuator configuration.

Selecting **4 mA** will make the valve fully closed when the signal is 4 mA and fully open when the signal is 20 mA.

Selecting **20 mA** will make the valve fully closed when the signal is 20 mA and fully open when the signal is 4 mA.

3. Pos. Characterization

Select **Linear** if the actuator position should be directly proportional to the input signal.

Select **Optional** if another characteristic is desired, which is set in conjunction with the next switch, labeled **Optional Pos. Char.**

4. Optional Pos. Char. – If the **Pos. Characterization** switch is set to **optional**, this switch is active with the following options:

The **=%** option will characterize the actuator response to the input signal based on a standard 30:1 equal percent rangability curve.

If **Custom** is selected, the positioner will be characterized to a custom table that must be set-up ValveSight DTM software or a HART handheld.

5. Auto Tune – This switch controls whether the positioner will auto tune itself every time the Quick-Cal button is pressed

On enables an auto tune feature that will automatically determine the positioner gain settings every time a Quick-Cal is performed based on the setting of the rotary **Gain** switch.

! **NOTE:** *there is a small black arrow indicating the selection. The slot does not indicate the chosen gain.*

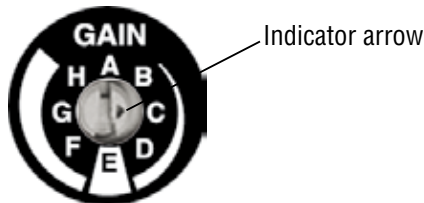

If the rotary **Gain** selector switch is set to **E** with the **Auto Tune** switch **On**, a Flowserve nominal response tuning set will be calculated and used.

If the rotary **Gain** selector switch is set to **D, C, B,** or **A** with the **Auto Tune** switch **On**, progressively lower gain settings will be calculated and used.

If the rotary **Gain** selector switch is set to **F, G,** or **H** with the **Auto Tune** switch **On**, progressively higher gain settings will be calculated and used.

Off forces the positioner to use one of the factory preset tuning sets determined by the rotary **Gain** selector switch. Settings **A** through **H** are progressively higher gain predefined tuning sets. The positioner is preset to Autotune - On at the factory. This is the recommended setting.

The gain selector operates as a “live” switch. This means that changes to the switch position while the positioner is in normal operation will have immediate effect on the control algorithm.

6. Stability Switch – This switch adjusts the position control algorithm of the positioner for use with low friction control valves or high friction automated valves

Placing the switch to the left optimizes the response for low friction, high performance control valves. This setting provides for optimum response times when used with most low friction control valves.

Placing the switch to the right optimizes the response for valves and actuators with high friction levels. This setting slightly slows the response and will normally stop limit cycling that can occur on high friction valves.

9.3 Calibration switches

9.3.1 Setup of the Cal DIP Switch for the Quick

Calibration operating mode

Select Auto if the valve/actuator assembly has an internal stop in the 100% stroke position. In Auto mode the positioner will fully close the valve and register the 0% position and then open the valve to the stop to register the 100% position when performing a self-calibration. See detailed instructions in the next section on how to perform an auto positioner calibration.

Select Jog if the valve/actuator assembly has no calibration stop in the open position. In the Jog mode the positioner will fully close the valve for the 0% position and then wait for the user to set the open position using the Jog buttons labeled with the up and down arrows. See the detailed instructions in the next section on how to perform a manual calibration using the Jog buttons.



WARNING: *During the Quick-Cal operation the valve may stroke unexpectedly. Notify proper personnel that the valve will stroke, and make sure the valve is properly isolated.*

9.4 Quick-Cal Operation

The **Quick-Cal** button is used to locally initiate a calibration of the positioner. Pressing and holding the **Quick-Cal** button for approximately three seconds will initiate the calibration. If the **Config-Switches** option is enabled, the settings of all the configuration switches are read and the operation of the positioner adjusted accordingly. The **Gain Selector** switch is also read and action will be taken to adjust the gain according to the settings of the calibration switches as described in the previous section. A **Quick-Cal** can be aborted at any time by briefly pressing the **Quick-Cal** button and the previous settings will be retained.

If the **Quick calibration** switch (not to be confused with the **Quick-Cal** button) is set to Auto and the valve/actuator assembly has the necessary internal stops, the calibration will complete automatically. While the calibration is in progress you will notice a series of different lights flashing indicating the calibration progress. When the lights return to a sequence that starts with a green light, the calibration is complete. (See the appendix for an explanation of the various light sequences.)



WARNING: When operating using local control of the valve, the valve will not respond to external commands. Notify proper personnel that the valve will not respond to remote command changes, and make sure the valve is properly isolated.

If the *Quick calibration* switch is set to *Jog*, the calibration will initially close the valve then cause a small jump in the valve position. **The jog calibration process will only allow the user to manually set the span; zero position is automatically always set at the seat.** If an elevated zero is needed a handheld or other PC based configuration software is required. The LEDs will then flash in a sequence of Y-G-Y-R (yellow-green-yellow-red) which indicates the user must now use the *Jog* keys to manually position the valve to the desired 100% position. Now press both *Jog* buttons simultaneously to proceed to the next step. The valve will then stroke and then wait while flashing the Y-G-Y-R sequence again, allowing the user to adjust the valve position a second time to exactly 100% using the *Jog* buttons. When the stem is properly positioned press both *Jog* buttons simultaneously again to register the 100% position and proceed. No more user actions are required while the calibration process is completed. When the lights return to a sequence that starts with a green light the calibration is complete. (See the appendix for an explanation of the various light sequences.)

9.5 Local control of valve position

Can be done from the user interface by holding both jog buttons and then simultaneously pressing the *Quick-Cal* button. While in this mode the LEDs will flash a Y-G-Y-Y (yellow-green-yellow-yellow) sequence. To exit the local control mode and return to normal operation, briefly press the *Quick-Cal* button.

9.6 Factory reset

Hold *Quick-Cal* button while applying power and all of the internal variables including calibration will be reset to factory defaults. The positioner must be re-calibrated after a factory reset. Tag names and other user configured limits, alarm settings, and valve information will also need to be restored. A factory reset will always reset the command source to analog 4-20 mA.

9.7 Special settings

Several adjustments to the Logix 520 such as split-range, MPC, soft stop, etc. cannot be set using the local interface.

To set these parameters please use ValveSight DTM software or a HART handheld.

10 4-20 MA ANALOG OUTPUT BOARD

The Logix 520MD digital positioner can be supplied to provide an analog feedback signal of the stem position.

This option can also be retrofitted in the field. The 4-20 mA analog output board is wired in series with a 12.5 to 40 VDC power supply (see Figure 5). This position feedback option has the following features and specifications:

Does not interfere with positioner operation.

Calibration of the analog output signal is performed using a HART 375 Handheld Communicator or configuration software such as ValveSight.

Output follows actual position of valve, including all failure modes of positioner except loss of power. An output of <3.15 mA is transmitted with loss of power to the positioner.

Immune to RFI/EMI disturbances.

Available for intrinsically safe applications (ATEX, FM, CSA).

10.1 Replacing the 4-20 mA Analog Output Board

To replace the 4-20 mA analog output board, refer to Figures 5 and 6 and proceed as outlined below. The following tools are required:

Phillips screwdriver



WARNING: Observe precautions for handling electrostatically sensitive devices.

1. Make sure the valve is bypassed or in a safe condition.
2. Disconnect the power and air supply to the unit.
3. Remove the main cover.
4. Remove the plastic board cover by removing the three retaining screws.
5. Remove the configuration board
6. Disconnect the two wire connection from the side of the 4-20 mA analog output board.
7. Gently lift the 4-20 mA analog output board off the main PCB assembly.
8. Align the two connectors on the new 4-20 mA analog output board with the mating sockets on the main PCB board and gently press the connectors together.
9. Connect the two wire connection coming from the User Interface board to the side of the 4-20 mA analog output board.
10. Replace the configuration board
11. Install the plastic board cover. Insert the three retaining screws through the plastic cover into the threaded boss and tighten evenly, using a Phillips screwdriver. Do not overtighten.
12. Connect the Analog Output wiring to the Analog Output terminals on the User Interface board (see Figure 5.)
13. Reinstall all covers.

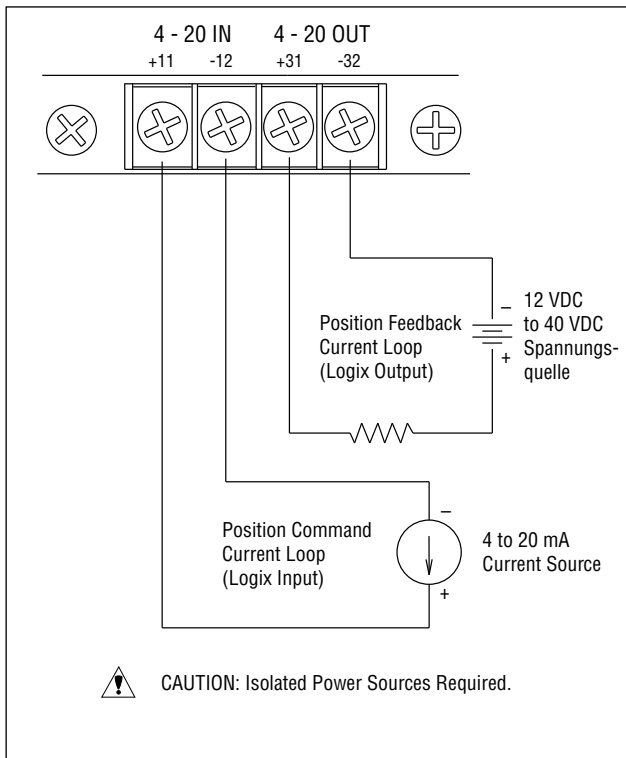

Figure 5: Analog Output Board Power



Figure 6: 4-20 mA Analog Output Board

11 LIMIT SWITCH UNIT



CAUTION: The installation of hazardous location electrical equipment must comply with the procedures contained in the certificates of conformance. Country specific regulations may apply. Electrical safety is determined only by the power supply device. (Positioner operation with limited voltage only).

11.1 General

The Logix 520MD digital positioner can be equipped with an additional limit switch unit.

11.2 Principle of Operation

The lever / coupling moves the vane into the slot of the limit switches LS1 or LS2. The sensors are designed as a proximity vane type switch. The switching function is triggered if a ferromagnetic object (vane) is inserted between the coils. The switching point can be set by adjustment of the vane.

11.3 Installation (Figure 7)

The limit switch unit is fitted to the positioner when delivered but can be retrofitted. Fit 3 spacer screws (1) to positioner housing. Place PC board (2) on spacer screws (1), secure with 3 mounting screws (3).

Switches (Figure 8)

Install vane assembly (4) and secure with 2 screws. For electrical connect see Figure 8.



WARNING: For units installed in Hazardous areas special installation cautions and procedures are required.

11.4 Adjusting switches

Use the following procedure to adjust the switches

1. Loosen the two screws on the vane (4), figure 7.
2. Stroke the valve to the first switching position.
3. Set the switching point of the limit switch by adjusting the lower vane for the lower switch (LS2).
4. Stroke the valve to the second switching position (LS1).
5. Set the switching point of the limit switch by adjusting the vane for the upper switch.
6. Tighten the two screws on the vane (4), figure 7.
7. Check the two switching points and repeat the adjustment steps 1 to 6, if necessary.

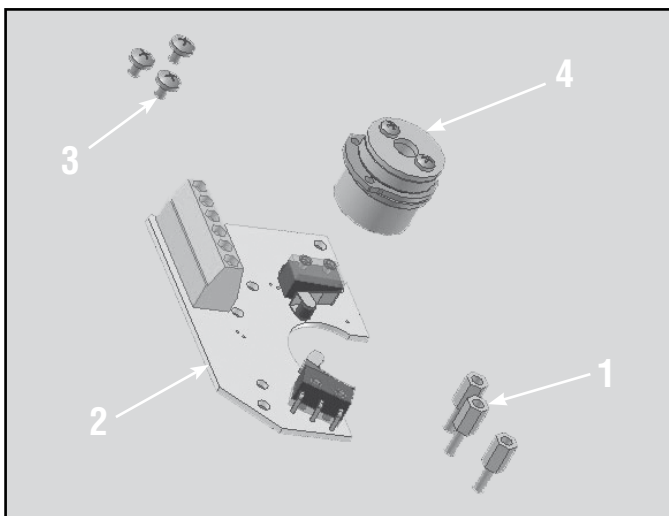

Figure 7: Limit switches

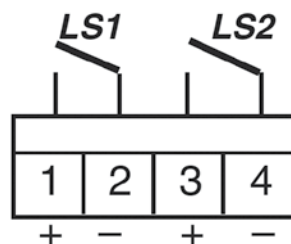
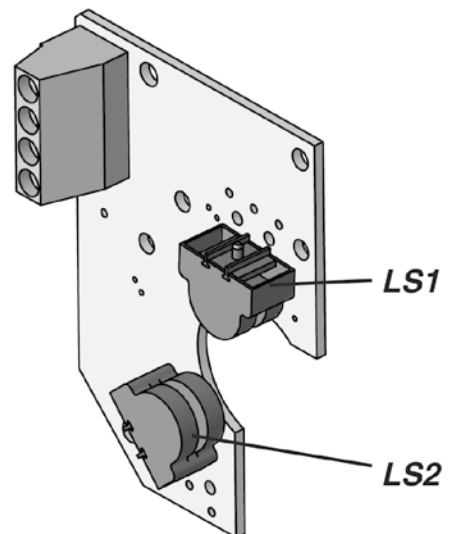

Figure 8: Switch connections

12 STATUS CODES

Blink Code	Description	Recommendations
GGGG	NORMAL OPERATION indicates normal, healthy operation	
GGGY	MPC ACTIVE MODE (user set) indicates that tight shutoff (MPC) is active. The command is beyond the user set limit for tight shutoff feature. This is a normal condition for all valves when closed. The factory default setting triggers this at command signals below 1%. This indication may also occur on 3 way valves at both ends of travel if the high MPC value has been set.	If tight shutoff is not desired reset the tight shutoff limits to the correct values or adjust the command signal inside of the specified MPC value. See DTM screen: Configuration/Custom/Position Cutoff.
GGYG	LOCAL INTERFACE DISABLED/ENABLED when DISABLED, indicates PC software has been used to disable the local interface. This code is only present for a short time when the Quick Cal button is pressed.	If local control is desired then the local interface must be re-enabled from the remote software. See DTM screen: Configuration/Basic Local Interface.
GGYY	DIGITAL COMMAND SOURCE indicates a HART signal is needed to change the position command and the analog 4-20 mA input signal is ignored.	A manual Command Source Reset is provided to change the command back to analog control mode from the local interface if a PC or hand held configurator is not available. This is done while a QUICK-CAL is in progress by holding down both the Jog buttons (up and down) while briefly pressing the QUICK-CAL button. A new QUICK-CAL must be done after resetting. See DTM screen: Dashboard.
GRRR	SQUAWK MODE ON/OFF (user set) When ON, this indicates a user has set the positioner to flash a special sequence so that it can be visually located.	This mode is canceled if the Quick-cal button is briefly pressed, the Squawk mode is selected again remotely, or more than one hour has passed since the command was issued. See DTM screen: Configuration/Custom/LED.
GYGG	POSITION LIMIT ALERT (user set) indicates the position has reached or is exceeding a user defined upper or lower position indicator similar to a limit switch indicator.	Reset the indicator if more travel is needed or adjust the command signal back in the specified range. See DTM screen: Configuration/Custom/Position Cutoff. This indicator can be disabled.
GYGY	SOFT STOP LIMIT ALERT (user set) indicates the unit is being commanded to exceed a user defined upper or lower position limit and the internal software is holding the position at the limit. The function is similar to a mechanical limit stop except it is not active if the unit is un-powered.	Reset the limit if more travel is needed or adjust the command signal back in the specified range. See DTM screen: Configuration/Custom/Soft Limits.
GRGG	CYCLES or TRAVEL LIMIT ALERT (user set) indicates that one of the cycle or travel limits has been exceeded. The criterion and count limit are set by the user to track the usage of the valve. There are accumulators for total valve travel, total valve cycles, total spool valve travel, and total spool valve cycles. Flowserve supplies software can identify the specific limit that has been reached.	For valve accumulators indications follow routine procedures for maintenance when the limit is reached such as checking the packing tightness, and checking linkages for wear, misalignment, and tightness. After maintenance, reset the cycle accumulator. See DTM screen: Health Status/Positioner Health. This indicator can be disabled. For spool valve accumulators inspect for high air consumption and signs of wear. See DTM screen: Health Status/Positioner Health. This indicator can be disabled.
YGGY	SIGNATURE IN PROGRESS MODE indicates that a test has been initiated by Flowserve supplied software	Signatures can only be canceled by Flowserve supplied software. See DTM screen: Diagnostics.
YGGR	INITIALIZING MODE displays a blink sequence 3 times when the unit is powering up.	Wait for power up to complete.
YGYG	CALIBRATION IS IN PROGRESS indicates a calibration is process. Calibrations such as stroke may be initiated locally with the Quick-Cal button or remotely. Other calibrations for the inputs and outputs or pressure sensors are only initiated remotely.	Local calibration may be canceled by briefly pushing the quick-cal button. Remote calibrations can only be canceled by the software.
YGYG	JOG COMMAND STATE indicates the unit has been placed in a local override mode where the valve can only be stroked using the two local jog buttons.	Control the valve using the jog buttons. This mode may be canceled by briefly pushing the quick-cal button.
YGYR	JOG CALIBRATION STATE indicates that during a jog calibration, the unit is waiting for the user to manually adjust the valve position to the desired 100% open position.	Use the buttons on the positioner to adjust the valve to the desired fully open position. See the explanation of Jog Calibrate in the Quick-Cal section of main document for operation.
YYGG	POSITIONER TEMPERATURE WARNING (user set) indicates the internal electronics have exceeded a temperature limit. The minimum limit of the electronics and the default setting is -40°F (-40°C). Low temperature may inhibit responsiveness and accuracy. The maximum limit of the electronics and default setting is 185°F (85°C). High temperature may limit the life of the positioner.	Regulate the temperature of the positioner. If the temperature reading is in error, replace the main board. See DTM screen: Health Status/Positioner Health. This indicator can be disabled.
YYGY	PRESSURE OUT OF RANGE WARNING indicates that during a pressure sensor calibration, the range of applied pressures to port 1 was too small for optimum performance.	Adjust the supply pressure to a proper value (30-150 psig) so the positioner can properly calibrate the sensors. Then recalibrate. Briefly push the quick-cal button to acknowledge this condition and the positioner will operate using the current short stroke calibration values if valid.
YYGR	SUPPLY PRESSURE HIGH WARNING indicates the positioner has determined that the supply pressure is above the user set warning limit.	Regulate the supply pressure at the positioner below the maximum limit recommended for your actuator. Recalibrate pressure sensors. Check the pressure sensor board connections. Replace pressure sensor board if necessary. See DTM screen: Health Status/Actuator Health. This indicator can be disabled.

Blink Code	Description	Recommendations
YYYG	SUPPLY PRESSURE LOW WARNING (user set) indicates that the supply pressure is below the user set warning limit. Low supply pressure can cause poor valve response or positioner failure. The minimum recommended supply pressure is 30 PSI (2.1 bar) for proper operation. The unit will fail at less than approximately 17 PSI (1.2 bars). Low supply pressure indications can also be caused by pneumatic leak.	Regulate the supply pressure at the positioner above 30 PSI (2.1 bar). Recalibrate pressure sensors. Ensure system air/gas supply is adequate. Repair kinked supply tubing. Check the pressure sensor board connections and replace pressure sensor board if necessary. Check for pneumatic leaks in the actuator and actuator tubing. See DTM screen: Health Status/Actuator Health. This indicator can be disabled.
YYYY	ACTUATION RATIO WARNING (user set) indicates a decreased ability of the system to actuate the valve. It is based on the ratio of available force to required force to actuate. It is affected by the process load, friction, spring force, and available supply pressure.	Increase the supply pressure. Reduce the friction. Check the actuator spring. Resize the actuator. Adjust user set limits. See DTM screen: Health Status/Actuator Health. This indicator can be disabled.
YRGG	PILOT RELAY RESPONSE WARNING (user set) indicates that the pilot relay is sticking or slow to respond. This affects the responsiveness, increases the chance of limit cycling and excessive air consumption. The pilot relay is part of the inner loop and consists of the driver module assembly with piezo (I-P relay) which is coupled to the poppet. The value of this indicator corresponds with inner loop lag. Delayed response can be caused by a partially clogged piezo or debris, oil, corrosion or low supply pressure.	Check response of the valve. If OK, adjust Pilot Relay Response limits. Check supply pressure. Replace the piezo or driver module assembly. Maintain a clean, water-free air/gas supply. See DTM screen: Health Status/Positioner Health. This indicator can be disabled.
YRGY	FRICITION LOW WARNING (user set) indicates the friction has passed below the user set limit.	Low friction is usually an indication of improperly loaded packing or seals in the valve and actuator. See DTM screen: Health Status/Valve Health. This indicator can be disabled.
YRGR	PNEUMATIC LEAK WARNING (user set) indicates that the positioner has detected a leak in the actuation assembly. Leakage from the actuator can cause decreased responsiveness and excessive air/gas consumption. Low supply pressure can also trigger this warning.	Repair pneumatic leaks at the tubing junctions and actuator seals. Ensure proper supply pressure. See DTM screen: Health Status/Actuator Health. This indicator can be disabled.
YRYG	FRICITION HIGH WARNING (user set) indicates the valve/actuator friction has passed the user set limit. High friction can cause loop oscillations, poor position control, jerky motion, or valve sticking. It can be caused by build-up from the process on the stem, trim or seat, by a failing bearing or guides in the valve and actuator, galling of the trim or stem, excessively tightened packing, linkages, or other valve/actuator mechanical issues.	Determine if the friction is significantly interfering with the valve control. If not, consider increasing the friction warning limit. Consider the following to reduce friction: Stroke the valve to clear off build-up. Clear any external mechanical obstruction, loosen the packing, clean the stem, repair or replace the actuator. Highly localized friction or very jerky travel can indicate internal galling. Repair or replace internal valve components. See DTM screen: Health Status/Valve Health. This indicator can be disabled.
YRRY	ELECTRONIC INABILITY TO FAIL SAFE WARNING indicates that the piezo may be damaged. This may prevent the proper failure position upon loss of signal/power. This condition may occur briefly on an air-to-close valve that is held for long periods of time in the closed position, or and air-to-open valve held in the open position.	If alarm persists for more than 30 minutes, the Piezo assembly is damaged and should be replaced. This indicator can be disabled.
YRRR	PNEUMATIC INABILITY TO FAIL SAFE WARNING indicates that upon loss of air supply, the valve may not move to the fail-safe position. The spring alone is not adequate to overcome the friction and process load in the system. The failsafe spring may have failed, or it was not sized properly for the application. Friction or process load may have increased.	Check for high friction. Repair or replace actuator spring. Reduce process load. This indicator can be disabled.
RGGY	FEEDBACK READING PROBLEM DURING CALIBRATION ALARM indicates that during calibration, the range of motion of the position feedback arm was too small for optimum performance, or the position sensor was out of range.	Check for loose linkages and/or adjust the feedback pin to a position closer to the follower arm pivot to create a larger angle of rotation if the feedback rotation is less than 15 degrees for the total valve travel and recalibrate. Briefly pushing the quick-cal button acknowledges this condition and the positioner will operate using the current short stroke calibration if otherwise a good calibration. If the condition does not clear then adjust the positioner mounting, linkage or feedback potentiometer to move the position sensor back into range then restart the calibration. This error may be cleared by briefly pushing the quick-cal button, which will force the positioner to use the parameters from the last good calibration.
RGGR	INNER LOOP OFFSET TIME OUT ALARM during calibration the Inner Loop Offset value did not settle. This could result in less accurate positioning.	Repeat the stroke calibration to get a more accurate ILO value. To proceed using the less accurate ILO value, this error may be cleared by briefly pushing the quick-cal button. Lowering the gain setting may help if the actuator is unstable during the calibration. Gain settings can be physically adjusted on the device. A lower letter represents lower gain.
RGYG	NON-SETTLE TIME OUT ALARM indicates that during calibration, the position feedback sensor did not settle.	Check for loose linkages or a loose positioner sensor. This error may be cleared by briefly pushing the quick-cal button, which will force the positioner to use the parameters from the last good calibration. This error may appear on some very small actuators during the initial calibration. Recalibrating may clear the problem.

Blink Code	Description	Recommendations
RGYG	NO MOTION TIME OUT ALARM indicates that during calibration, there was no motion of the actuator based on the current stroke time configuration.	Check linkages and air supply to make sure the system is properly connected. If the time out occurred because the actuator is very large then simply retry the Quick cal and the positioner will automatically adjust for a larger actuator by doubling the time allowed for movement. This error may be cleared by briefly pushing the quick-cal button, which will force the positioner to use the parameters from the last good calibration.
RGRG	FACTORY RESET STATE indicates the unit has had a factory reset and has not yet been calibrated. The unit will not respond to commands and will remain in the failsafe position until a calibration is successfully completed.	Calibrate. Proper Valvesight operation will require stroke, actuator, and friction calibration to be completed. This indicator can be disabled.
RYYG	SUPPLY PRESSURE LOW ALARM (user set) indicates that the supply pressure is below the user set alarm limit. Low supply pressure can cause poor valve response or positioner failure. The minimum recommended supply pressure is 30 PSI (2.1 bar) for proper operation. The unit will fail at less than approximately 17 PSI (1.2 bars). Low supply pressure indications can also be caused by pneumatic leak.	Regulate the supply pressure at the positioner above 30 PSI (2.1 bar). Recalibrate pressure sensors. Ensure system air/gas supply is adequate. Repair kinked supply tubing. Check the pressure sensor board connections and replace pressure sensor board if necessary. Check for pneumatic leaks in the actuator and actuator tubing. See DTM screen: Health Status/Actuator Health.
RRGG	PILOT RELAY RESPONSE ALARM (user set) indicates that the pilot relay is sticking or extremely slow to respond. This affects the responsiveness, increases the chance of limit cycling and excessive air consumption. The pilot relay consists of the driver module assembly with piezo (I-P relay) which is coupled to the spool valve. Delayed response can be caused by a partially clogged piezo or debris, oil, corrosion, or ice on the spool, or low supply pressure.	Check response of the valve. If OK, adjust Pilot Relay Response limits. Check the supply pressure. Check the spool for debris, oil, corrosion, ice on the spool. Clean or replace the spool assembly. Replace the piezo or driver module assembly. Maintain a clean, water-free air/gas supply. See DTM screen: Health Status/Positioner Health. This indicator can be disabled.
RRGY	FRICTION LOW ALARM (user set) indicates the friction has passed below the user set limit. The alarm indicates a more severe condition than the warning.	Check for a packing leak. Tighten or replace the valve packing. See DTM screen: Health Status/Valve Health. This indicator can be disabled.
RRGR	FRICTION HIGH ALARM (user set) indicates the valve/actuator friction has passed the user set limit. The alarm indicates a more severe condition than the warning. High friction can cause loop oscillations, poor position control, jerky motion, or valve sticking. It can be caused by build-up from the process on the stem, trim or seat, by a failing bearing or guides in the valve and actuator, galling of the trim or stem, excessively tightened packing, linkages, or other valve/actuator mechanical issues.	Determine if the friction is significantly interfering with the valve control. If not, consider increasing the friction warning limit. Consider the following to reduce friction: Stroke the valve to clear off build-up. Clear any external mechanical obstruction, loosen the packing, clean the stem, repair or replace the actuator. Highly localized friction or very jerky travel can indicate internal galling. Repair or replace internal valve components. See DTM screen: Health Status/Valve Health This indicator can be disabled.
RRYG	PIEZO VOLTAGE ALARM indicates the portion of the circuit board that drives the piezo is bad, or piezo valve itself is bad.	If the unit is functioning and controlling replace the piezo, if it does not operate replace the main circuit board. This indicator can be disabled.
RRYR	PILOT RELAY POSITION LIMIT ALARM indicates the pilot relay (spool) appears to be fixed at a limit and is not responding. This could be due to low supply pressure, a hall sensor that is out of calibration, a broken piezo, stuck spool, or a wire connection problem.	Check for adequate supply pressure. A hall sensor problem may be cleared by briefly pushing the quick-cal button, which will force the positioner to use the parameters from the last valid calibration. Check the internal wiring harnesses for good connections. Check the spool valve for sticking problems. If the positioner still does not operate replace the piezo, driver module assembly, and/or spool assembly.
RRRY	ELECTRONICS ERROR OR ALARM indicates the internal data was not updated correctly. This may affect the function of the positioner in various ways or not at all. This can be caused when intermittent operation occurs when connecting power.	Error may self clear with time. If error persists, cycle power and complete a Quick-Cal. If the error still persists, Check internal wiring and connectors for electrical shorts or opens. If no problems are found and alarm persists, replace the main circuit board.
RRRR	POSITION DEVIATION ALARM (user set) indicates the difference between the command and the actual position has been greater than the user-set limit for longer than a user-set time.	Review active alarms and warnings to find root causes of this alarm. See DTM screen: Alerts/Command Deviation. This indicator can be disabled.

13 VERSION NUMBER CHECKING

The version number of the embedded code may be checked at any time except during a calibration by holding down the Δ button. This will not alter the operation of the unit other than to change the blink sequence to 3 blinks indicating the major version number. Holding the ∇ button will give the minor version number without affecting operation. The version codes are interpreted by adding up the numbers assigned according to the following table:

Color	First blink value	Second blink value	Third blink value
Green	0	0	0
Yellow	9	3	1
Red	18	6	2

For example if holding the Δ button gave a G-G-R code, and holding the ∇ button gave a Y-Y-G code then the resulting version number would be (0+0+2).(9+3+0) or version 2.12.

14 TROUBLE SHOOTING

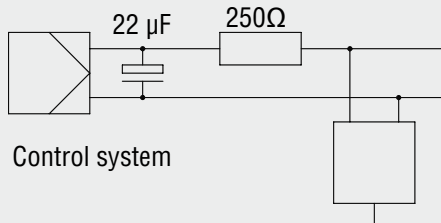
Logix 520MD Symptoms and Solutions		
Failure	Probable Cause	Corrective action
No LED is blinking	<ol style="list-style-type: none"> 1. Current source below 3,7 mA 2. Incorrect wiring polarity 	<ol style="list-style-type: none"> 1. Verify current source supplies at least 3,7 mA 2. Check wiring for correct polarity
Erratic communications	<ol style="list-style-type: none"> 1. Current source bandwidth not limited to 25Hz 2. Maximum cable length or cable impedance exceeded 3. HART modem connected to PC RS-232 port not receiving enough power 4. Interference with I.S. barrier 5. Current source stripping (filtering) HART signal 	<ol style="list-style-type: none"> 1. Maximum allowable current source rate of change is 924 mA per second 2. Check cable conductor size, length and capacitance. Refer to 'Cable Requirements' on page 11. 3. Verify laptop battery is not low 4. Must use HART compatible I.S. barrier 5. Use the HART filter (VHF) available from Flowserve (FLS part-No. 10156843) Alternatively a 250Ω and a 22 μF capacitor, installed according to the following schematic drawing can be used to establish communication 
Unit does not respond to analog commands	<ol style="list-style-type: none"> 1. Unit is in digital command mode 2. Error occurred during calibration 	<ol style="list-style-type: none"> 1. Switch to analog command mode with ValveSight DTM software or handheld communicator. 2. Correct calibration error. Recalibrate
Valve position reading is not what is expected	<ol style="list-style-type: none"> 1. Stem position sensor mounting is off 180 degrees 2. Stroke not calibrated 3. Tight shutoff MPC (Minimum position cutoff) is active 4. Custom characterization or soft stops active 	<ol style="list-style-type: none"> 1. Reposition sensor 2. Calibrate stroke 3. No action 4. No action
Position is driven fully open or closed and will not respond to command	<ol style="list-style-type: none"> 1. Stroke not calibrated 2. Inner-loop hall sensor not connected 3. Wrong air action entered in software 4. Actuator tubing backward 5. Electro-pneumatic converter malfunctioning 6. Control parameter inner-loop offset is too high/low 	<ol style="list-style-type: none"> 1. Calibrate valve stroke 2. Verify hardware connections 3. Check ATO (Air-to-open) and ATC (Air-to-Close) settings. Recalibrate 4. Verify ATO/ATC actuator tubing 5. Replace electro-pneumatic converter 6. Adjust inner-loop and see if proper control resumes
Sticking or hunting operation of the positioner	<ol style="list-style-type: none"> 1. Contamination of the electro-pneumatic converter. 2. Control tuning parameters not correct 	<ol style="list-style-type: none"> 1. Check air supply for proper filtering and meeting ISA specifications ISA-7.0.01 2. Lower proportional gain settings

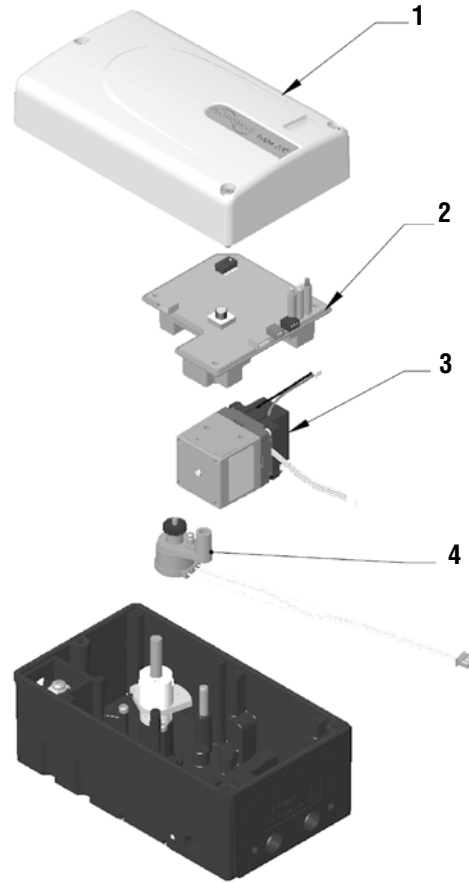

Figure 9: Exploded drawing for spare parts

15 SPARE PARTS KITS

Item No.	Description	Part-No.
1	Cover Assembly	Yellow
		White
		Black
2	PC Board Assembly Logix 520MD	255240.999.000
	PC Board Assembly analog feedback board	218771.999.000
3	Relay Module Assembly: -20°C to 85°C (-4°F to 185°F)	255463.999.000
	Relay Module Assembly: -40°C to 85°C (-40°F to 185°F)	230103.999.000
4	Repair kit for Potentiometer Assembly	218773.999.000
5	Position Feedback Assembly	218774.999.000
8	Follower Arm Assembly	Max. stroke 65 mm
		Max. stroke 110 mm

Mounting Kits

	Description	Part-No.
-	IEC 534 part 6 (FloTop, Kämmer KA, Kämmer KP, and standard NAMUR linear valves)	213619.999.000
-	Rotary VDI/VDE 3845 (DIN ISO 5211)	188151.999.000
-	Flowserve direct mounting	214004.999.000
-	Linear VDI / VDE 3847	255242.999.000

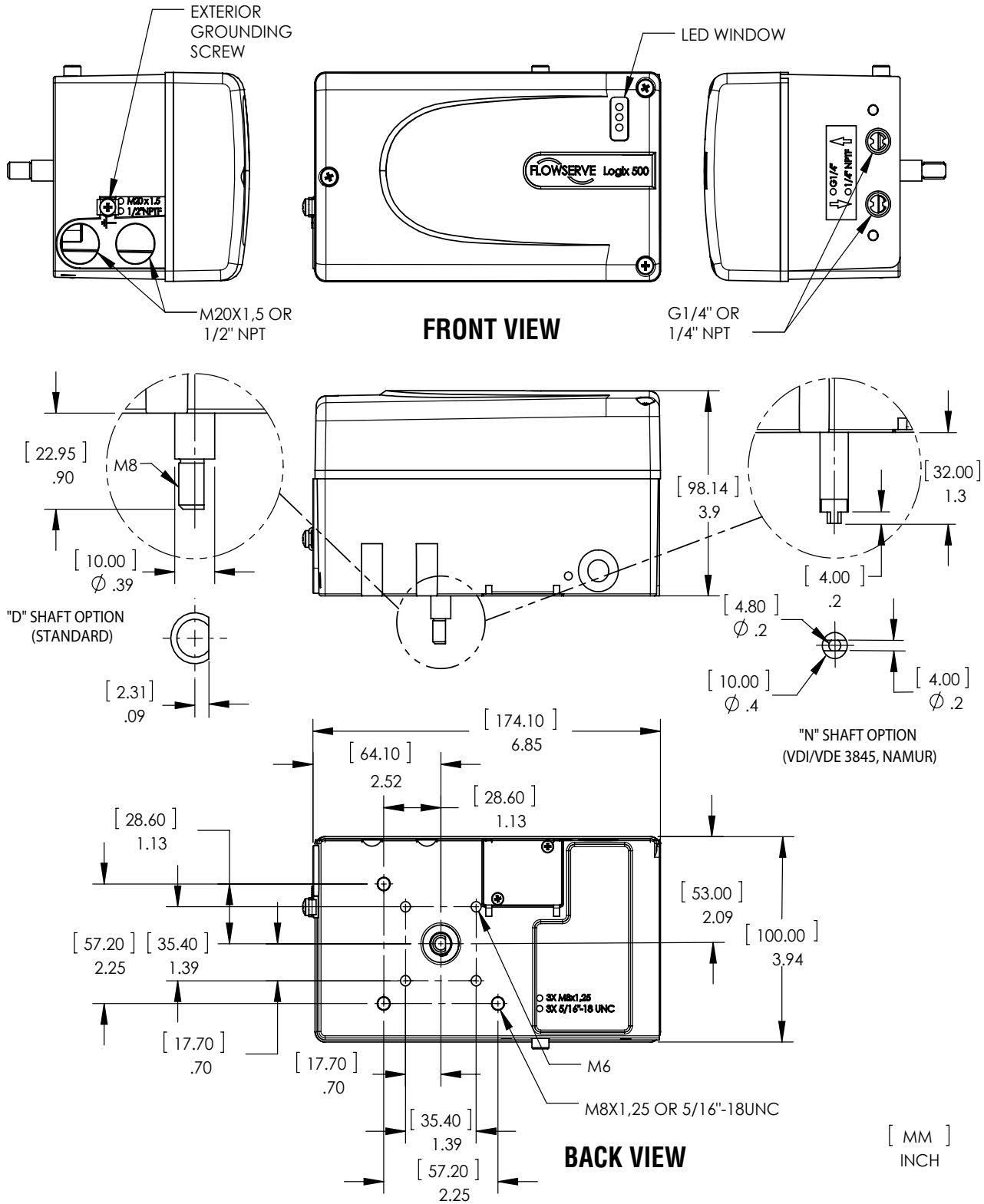
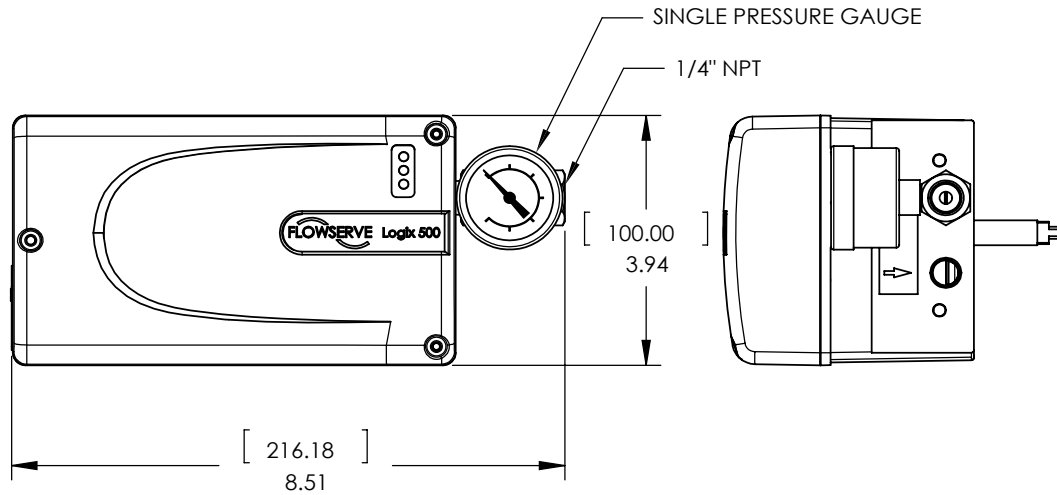
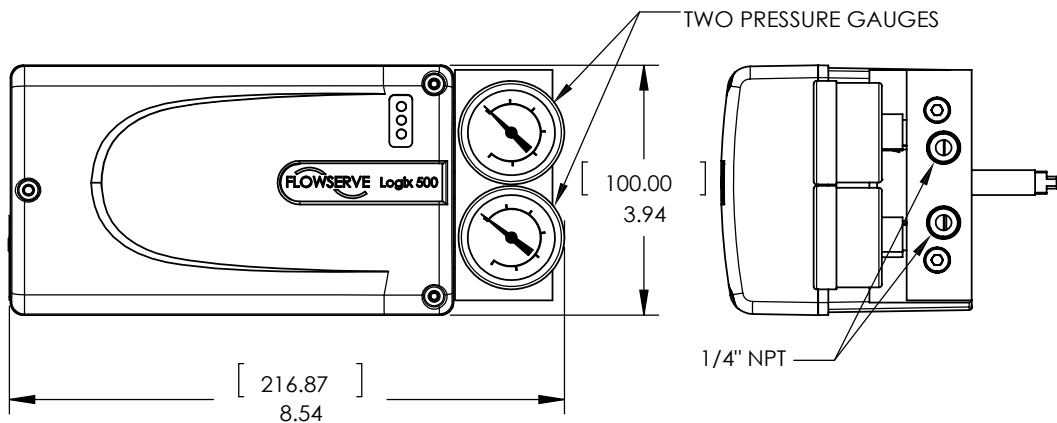

Figure 10: Dimensional Drawing for the Logix 520MD Series Digital Positioner



AUXILIARY OPTIONS - "GA" (GAUGE ADAPTER)



AUXILIARY OPTIONS - "GM" (GAUGE MANIFOLD)

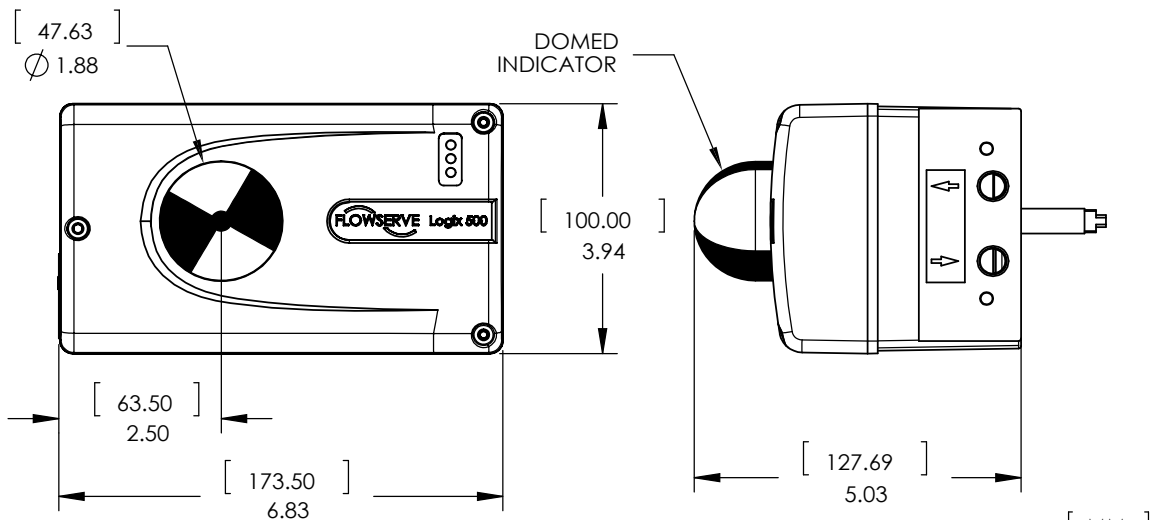

POSITION INDICATOR - "D" (DOMED INDICATOR)

[MM]
INCH

Figure 11: Dimensional Drawing for the Logix 520MD with options